

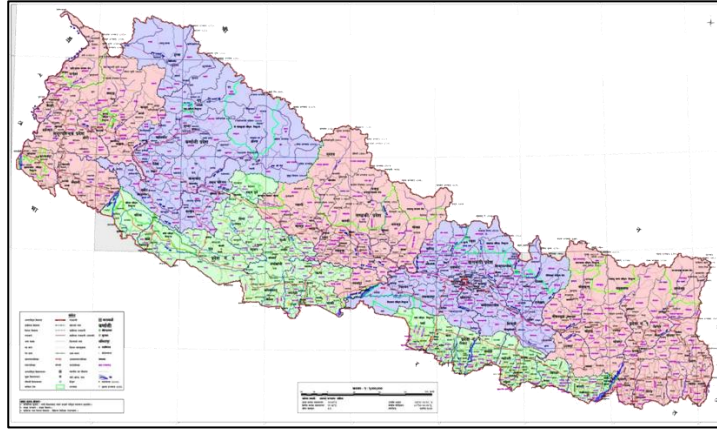

# NEPAL NATIONAL BUILDING CODE

## NBC 206:2024



## ARCHITECTURAL DESIGN REQUIREMENTS

Compliance with it does not confer immunity from relevant legal requirements, including bylaws.

मिति २०८१।०१।२५ को नेपाल सरकार (मन्त्रीस्तरीय) निर्णयानुसार स्वीकृत र मिति  
२०८१।०२।१४ को नेपाल राजपत्रमा सूचना प्रकाशित

Government of Nepal  
Ministry of Urban Development  
**Department of Urban Development and Building Construction**  
Babar Mahal, Kathmandu, Nepal  
2081



## 2. Expert Committee for Review& Update

Ar. Padma Mainalee	Joint Secretary, Ministry of Urban Development
Ar. Sarita Shrestha	Expert
Ar. Rajni Shrestha	Expert

## 3. Working Committee

Ar. Prakash Aryal	Kathmandu District Commissioner, KVDA
Er. Manoj Nakarmi	SDE, DUDBC
Ar. Nisha K.C.	Er., DUDBC
Ar. Rajesh Shrestha	Expert
Ar. Arun Dev Pant	Expert

## 4. Inputs to this revision came from:

Er. Dilip Bhandari	Joint Secretary, MOUD
Er. Narayan Prasad Bhandari	DDG, Urban Development, DUDBC
Er. Prakirna Tuladhar	DDG, Building Division, DUDBC
Er. Machakaji Maharjan	DDG, Housing Division, DUDBC
Ar. Rajendra Khatiwada	SDE, DUDBC
Ar. Raju Neupane	SDE, DUDBC
Ar. Pratigya Manandhar	SDE, DUDBC
Ar. Kishore Shrestha	SDE, DUDBC
Ar. Reeta Kafle	SDE, DUDBC
Er. Debendra Dev Khanal	Er., DUDBC
Er. Madhav Katuwal	Er., DUDBC
Ar. Astha Acharya	Er., DUDBC
Ar. Trilochan Adhikari	Ar., DUDBC

We would like to express our sincere thanks to all those who contributed directly and indirectly for the revision of this code. We hope the revised code will be able to address the issues on the architectural design of buildings as it incorporates the recent knowledge and technology in the sector.

# Contents

1. TERMINOLOGY .....	1
1.1 General Terms .....	1
1.2 Classification of Building .....	3
1.2.1 Based on Occupancy .....	3
1.2.2 Based on Storey & Height .....	6
2. MEANS OF EXIT .....	7
2.1 Occupant Load .....	7
2.2 General Exit requirement.....	8
2.2.1 Exit Doors.....	8
2.3 Corridors and Passageways .....	9
2.4 Staircase & Ramps .....	9
2.4.1 General Staircase Requirements.....	11
3. COMPONENTS OF THE BUILDINGS .....	12
3.1 Plinth .....	12
3.2 Minimum Room Dimensions .....	12
3.2.1 Height .....	12
3.2.2 Size .....	12
3.3 Light & Ventilations .....	13
3.4 Lifts .....	13
3.5 Basements.....	15
3.6 Parking.....	16
4. SPECIFIC REQUIREMENTS FOR MULTI STOREY BUILDINGS .....	17
4.1 Medium Rise .....	17
4.2 High Rise.....	17
5. ACCESSIBILITY FOR DISABLED .....	19
5.0.1 Requirements for Wheel chair bound people.....	19
5.1 Category 1: Minimally Accessible .....	19
5.2 Category 2: Partially Accessible.....	20
5.3 Category 3: Fully Accessible.....	22
6. SUMMARY OF REQUIREMENTS BASED ON OCCUPANCY .....	23
6.1 Residences .....	23
6.2 Assembly .....	24
6.3 Educational .....	25
6.4 Hospitals and Clinic .....	27
6.5 Commercials & Office .....	28
6.6 Industries & Storage .....	29
A. REFERENCES.....	30
B. GENERAL CHECKLIST FOR NBC-206.....	31

## **1. TERMINOLOGY**

### **1.1 General Terms**

#### **1.1.1 Building:**

Any Structure constructed of whatever material, whether used as human habitation or not and which includes foundation, plinth, walls, floors, roofs & building services. Temporary structures like tents, tarpaulin shelter etc. shall not be considered as buildings.

#### **1.1.2 Public Buildings:**

Public Buildings refer to all the government, non-government or private buildings which are used for providing services, facilities, products and opportunities to the general public.

#### **1.1.3 Building Height:**

The Height of the building shall mean the vertical distance from the plinth level to the terrace of the upper most floor in case of a flat roofed building, to the center of the highest sloped part in case of buildings with the slope greater than 30° and to the eaves level of the highest sloped part in case of building with slope less than 30°. To consider Building Height from plinth, maximum plinth height shall be 900 mm. To exclude height of floor consisting staircase cover only from building height, the height of floor consisting staircase cover only shall be summation of 2.1m and beam depth. Building height may exclude any structure to hold the water tank, lift cover, parapet or any decorative elements. Building Height exclusion however shall not exceed the minimum required for the lift cover plus 1200 mm for the parapet above the lift cover.

#### **1.1.4 Plinth:**

Plinth means part of the building above the normal ground level and below the ground floor level.

#### **1.1.5 Plinth Area:**

Plinth Area refers to area occupied by the ground floor of the building. Plinth area also includes the area occupied by any structural elements of the building even if they are present outside the main building. The Plinth Area may not include the atrium area or any voids greater than 1.5m x 1.5m. It however includes external areas which are covered by cantilevers and are part of the circulation of building.

#### **1.1.6 Built-Up area**

Built-up area shall be the sum of all the floor areas in the building used for one or more occupancy type. The Built-Up area shall include all the area of the building that comes under FAR as per local byelaws.

#### **1.1.7 Habitable Rooms**

A room occupied or designed for occupancy by one or more people for the purpose of study, living, sleeping, eating, and cooking. This excludes spaces that are not used frequently or for long periods like toilet, bathroom, laundry, store, pantry, corridor, cellar and attic.

#### **1.1.8 Floor Height**

Floor height refers to height of the room measured from the surface of the floor to the lowest point of the ceiling.

**1.1.9 Basement**

The lower story or story of a building that are either completely below the average ground level or extending up to 1.2 m above the ground level.

**1.1.10 Refuge Area**

An area of refuge is a particular designated location in a building designed to hold occupants during a fire or other emergency, when evacuation may not be safe or possible. Occupants can wait there until the arrival of the rescue team. They are necessary in high rise buildings with building height greater than 25 m which is beyond the reach of normal fire brigade.

## **1.2 Classification of Building**

### **1.2.1 Based on Occupancy**

All buildings shall be classified according to the use or the character of occupancy into one of the following groups. This classification may be used by other codes as required:

Group A: Residential

Group B: Assembly

Group C: Educational

Group D: Hospitals & Clinic

Group E: Commercial

Group F: Office

Group G: Industries

Group H: Storage

#### **Group A: Residential**

This shall include any building in which sleeping accommodation is provided for normal residential purpose with or without cooking or dining or both facilities. Indigenous and vernacular residential buildings and NBC type C buildings may be allowed to exempt from these rules.

Residential Buildings are further divided into:

##### **Sub Group A1: General residence**

This shall include any private residential building which has sleeping accommodation for not more than 40 persons. Based on occupancy load [Table 1], this relates to residential buildings having built-up area less than 500 sq.m, beyond which any residential buildings shall be classified under A4.

##### **Sub Group A2: Residential with limited commercial use**

This may include Residential buildings; with plinth area less than 150 sq.m and where part of the building has been used for commercial or office purpose.

##### **Sub Group A3: Residential Apartments**

This shall include any building or structure which provides residential units in a single building for three or more families, living independently of each other.

##### **Sub Group A4: Dormitories and Hotels**

These shall include any buildings under single management in which sleeping accommodation is provided with or without dining facilities for more than 10 persons. Any residential building with occupancy loads greater than 40 persons is required to fulfill the requirement of this group. All the hotels shall fulfill the minimum requirements for this group.

#### **Group B: Assembly**

Assembly building shall include any building or part of building, which is designed for gathering of 50 or more people. These shall include, theatres, cinema halls, auditorium, party palaces, exhibition halls, museums, gymnasiums, covered hall, conference and meeting halls (above 50 capacity) and

other buildings or spaces within buildings where more than 50 persons are expected to assemble. Assembly buildings shall be sub-divided into 2 groups:

Sub Group B1: Assembly buildings and spaces with capacity up to 500 people

Sub Group B2: Assembly buildings and spaces with capacity above 500 people

### **Group C: Educational**

Educational building shall include any buildings used as school, college, training institutes intended for more than 25 students at a time. Educational buildings shall be divided into two categories:

Sub Group C1: Primary Schools (up to standard 5)

Sub Group C2: Secondary Schools (beyond standard 5)

Any classroom with more than 50 students should be treated as an assembly unit and shall be provided means of exit as such.

### **Group D: Hospitals and Clinics**

Group D shall include all medical and health institutions which are intended to house persons suffering from physical or mental illness disease or infirmity, or to provide care for infants or aged persons. Smaller clinics with area less than 100 sq.m where the patients are not expected to stay may be excluded from this. However, all public health post should fulfill the Category 2 of disabled accessibility requirements as specified in Part 5.

Hospitals and Clinics shall be divided into two categories:

Sub Group D1: Medical Institutions with less than 25 beds

Sub Group D2: Medical Institutions with more than 25 beds

### **Group E: Commercial**

Group E shall include all the buildings or the part of the buildings designated for commercial use which includes uses such as shops, markets, sale of merchandise either whole sale or retail, malls, Departmental store.

Residential normal rise buildings with plinth area less than 150 sq.m where part of the building has been used for commercial use may be categorized under subgroup-A 2 as *Residential with limited commercial use*.



**Group F: Offices**

These shall include any building or part of building which is used for official or business use. Residential normal rise buildings with plinth area less than 150 sq.m where part of the building has been used as offices may be categorized under subgroup- A2 as *Residential with limited commercial use*.

**Group G: Industries**

Group G shall include any building or part of the building or structure in which products or material of all kinds and properties are fabricated, assembled, manufactured or processed. Certain type of industries may be more hazardous than other hence require a different fire safety measure. The categorization of the Industries based on fire load [which is the measure of the maximum heat that would be released if all combustibles in a given fire area burn] shall be dictated by Fire safety code 107.

**Group H: Storage**

These shall include any buildings used primarily for the storage of goods, ware or merchandise, cars or animals and which are non-hazardous. Storage buildings in general have lower occupancy in proportion to area for most of the time.

Some store may house more hazardous than other hence require a different fire safety measure. The categorization of the storage buildings and areas based on fire load [which is the measure of the maximum heat that would be released if all combustibles in a given fire area burn] shall be dictated by Fire safety code 107.

## **1.2.2 Based on Storey & Height**

### **Group S1: General Buildings**

Criteria- 1 to 5 Stories or below 18m

General buildings include those whose height are within reach of fire fighters' ladders and hose streams. The height of the building is comfortable to travel without the use of lifts. This is by far the most common type of built form overall.

### **Group S2: Medium Rise**

Criteria- 6 to 8 Stories or between 18m to below 25m

Medium Rise includes buildings whose heights are within the reach of fire hose streams. In the case of an emergency, rescue thorough stairways by firefighter are possible.

### **Group S3: High Rise**

Criteria- 9 to 39 Stories or 25m to below 100m

High rise includes buildings that are beyond the reach of normal firefighting provision on the ground. In case of emergency the rescue operation shall require the use of fire lift/s and/or fire staircase/s in the upper floors.

### **Group S4: Skyscrapers**

Criteria- 40 Stories and above or above 100m

Skyscrapers require a new approach in terms of safety, design and technology used and have not been experimented in Nepal till date hence are not covered by this code. It is expected that they be covered by a separate guideline after appropriate research.

## 2. MEANS OF EXIT

This part of the code defines the requirement for various components which forms the part of the exit system of the building. Exits shall be defined as a continuous and unobstructed means of egress to a public way. The means of exit includes the following:

A. Doors and openings – Exit Medium

B. Passageways and corridors

C. Stairways and ramps

Exit Route

The requirements are guided primarily by ease of evacuation but shall also address minimum level of function and accessibility.

### 2.1 Occupant Load

The requirement of exit system is based on number of occupants in the building or at each floor level or at each occupancy zone within the building. The designer should calculate occupant load as if all of the area is occupied to determine the maximum possible number of occupants to be accommodated by the exit system.

**Table 1- Maximum Floor Area Allowances per Occupant**

Building Type		Max. area per occupant [Sq.m]- A	Minimum Occupants per 100 sq.m [example]
A.	Residence		
A1	General	11.5	9
A2	Residential with limited commercial use	9	12
A3	Residential Apartments	18	6
A4	Dormitory & Hotels	4.5	23
B.	Assembly		
	Fixed seating	As per no. of fixed seats	
	Without fixed seat	1.4 net	72
C.	Educational	4.0	25
D.	Hospitals & Clinics	14	8
E.	Commercial		
	Main floors & Basement	2.75	37
	Areas on other floors	5.5	19
F.	Office & Industries	9	12
G.	Storage/warehouse	28	4

The occupant load of the building or area within the building can be calculated using the relation below.

$$\text{Occupant Load of the building or area} = \frac{\text{Net or gross area}}{\text{Area per occupant}}$$

- In any case the allocated area per occupant shall not be more than that specified under table 1-A. The building can however be designed for higher occupant load by allocating lesser area per occupant.
- Fractional occupant for each use shall be rounded up to the next whole number.

- In case an area is used for dual purpose, the value which gives max occupant load shall be considered. In case of multiple occupancy use within the single building, the individual occupant load shall be calculated and added up.
- The words 'gross' and 'net' areas are specific to certain occupancy type. Gross floor areas include all the area including the rest rooms, internal corridors and any subsidiary rooms while net areas include just the areas where the occupants reside.
- For calculation of the width of main doorways and corridors at exit level and the width of the stairways, the effective occupant load shall be 1.5 times of occupant load of the same floor.

## **2.2 General Exit requirement**

- A. The maximum travel distance to exits or stairways from any point within the single floor level shall not be more than 30m for all types of building except when external corridor of 15m or more is part of the route, in which this distance may be increased to 40m. However, it may be noted that external corridor is not allowed as medium of passage in case of High-rise buildings unless they are fully enclosed by a glazed medium in which case it is considered as enclosed.
- B. All exits shall be free of obstructions.
- C. Exits shall be arranged in a way that they may be reached without passing through another enclosed occupied area except in case of residential and apartment buildings.
- D. All exit components shall be properly illuminated as far as possible. Illuminated exit signs shall be required for occupancy Groups B1, D2, high rise buildings and category 3 disabled accessible buildings.

### **2.2.1 Exit Doors**

- A. No exit door, inclusive of frame, shall be less than 1m in width and 2.1m in height except in case of residences where the minimum size of exit door shall be 0.9m in width by 2m height. The width of doors of rooms which do not form a part of general human habitation or exit medium such as toilets and verandah is permitted to width of 0.75m.
- B. In case of Assembly and Educational buildings minimum of two doors shall be provided if the no. of occupants in the room is greater than 50.
- C. Exit doorway of Assembly buildings and fire exit door of all type of buildings shall be openable without a key from the inner side.
- D. The doors shall not obstruct the passages and staircase landings when open.
- E. Exits for disabled shall be as specified under Part 5.
- F. The width of the doorways shall be measured in multiple of 500mm and calculated using table 2.

The width of the exit doorways and openings from the occupancy area at each level should be based on the occupancy load at that level and can be calculated using table 3. However, it should not be smaller than as specified under heading 2.3.

The width of main doorways leading to exterior shall be based on the 1.5 times of occupant load of the floor.

**Table 2–Exit Door/s Width Calculation Table**

	A	B	C
	Minimum Width(m)	Occupant per unit 500mm width- A	No of occupants when exit medium width exceeds the min. limit-B
<b>Residences</b>			
General	0.9	75	135
Apartments/ Dormitories	1.0	75	150
Assembly	1.2	90	216
<b>Educational</b>			
Primary Schools	1.0	75	150
Secondary Schools	1.2	75	180
Hospitals and Clinics	1.2	75	180
Commercial	1.0	75	150
Office	1.0	75	150
Stores	1.0	75	150

Steps for calculation of width of Doorways:

- Determine the occupant load of the building, floor or the section where the doorway is to be provided.
- If occupant load is not known, it can be calculated using table 1.
- If the no. of occupants is less than what is specified in column C of table 2, then use the minimum standard width as given under column A.
- If the no. of occupants exceeds the figure, then use the formula below to calculate the width of the exit medium

$$\text{Required width of the exit medium} = \frac{\text{Occupant Load} \times 0.5}{\text{Occupant pers standard unit [B]}}$$

- The calculated exit width can be divided into two or more exits given that the widths or each are not less than what is specified under table 2 A.
- For disabled accessible buildings or sections of the buildings, ensure that the width of the exit comply to the standards under section 5.

### 2.3 Corridors and Passageways

Corridors and Passageways connect doorways to staircase and ramps.

- A. Width of corridors and passageways at each floor shall be based on the occupant load of that floor and can be calculated using table 3 but it should not be smaller than what is specified in column A of Table 3.
- B. Width of main corridor and passage way to which the staircase opens shall be based on the 1.5 times of occupant load of the floor.

### 2.4 Staircase & Ramps

- Capacities of stairways and ramps at any level shall be based on the 1.5 times of occupant load of floor, while not being smaller than what is specified under column A of Table 3.

The width of the exit route shall be calculated from the table below:

**Table 3 Width of the Corridors, passageways, Staircase and ramps**

Occupancy Type	A Minimum Width (m)	B Occupant per 500mm width [For ramps add 10 occupants]	C No of occupants when stairway width exceeds the min. limit
<b>Residences</b>			
General	0.9	25	45
Residence with limited Commercial use	1	30	60
Apartments/ Dormitories	1.2	25	60
<b>Assembly</b>			
Below 500 capacity	1.5	60	180
Above 500 capacity	2	60	240
<b>Educational</b>			
Primary Schools	1.2	25	60
Secondary Schools	1.5	25	75
<b>Hospitals &amp; Clinics</b>			
Stretcher & equipment accessible	2.2		
<b>Commercial</b>			
Medium/ Highrise	1.25	50	125
Office	1.5	50	150
Medium/ Highrise	1.25	50	125
Stores	1.5	50	150

*Steps for calculation of width of Exit Route:*

- For all buildings, width of staircases and ramps shall be based on the 1.5 times occupant load of the floor.
- If occupant loads are not known, it can be calculated using table 1.
- If the no. of occupants is less than what is specified in column C of table 3 then use the minimum standard width directly.
- If the no. of occupants exceeds the figure, then use the formula below to calculate the width of the exit route  

$$\text{Required width of the Corridors, passageways, staircase \& Ramps} = \frac{\text{OccupantLoad} \times 0.5}{\text{Occupant per standard unit [B]}}$$
- The calculated exit route width can be distributed into two or more exits given that the widths are not less than what is specified under table 3 A

For reduced use staircases which are not part of the normal exit system such as accesses to lofts, attics and terraces, the minimum width shall be 600mm.

### 2.4.1 General Staircase Requirements

- For all buildings above 500 sq.m in plinth area there shall be at least two staircases. Additional exit route shall be provided for every 500 sq.m of the plinth area there on.
- Specific Stairways requirement for medium rise and high-rise buildings are provided under respective headings.
- Any High-rise building above 50 m shall have one pressurized staircase as dictated by the 'Fire safety code'.
- All secondary or fire escape staircase shall have at least one side facing towards exterior.

All staircases except those that are meant for reduced use and not the part of exit system staircases such as accesses to lofts, attics and terraces shall conform to following requirements.

**Table 4 Staircase Details**

<b>Minimum Tread–A</b>	
Residences	250mm [10"]
Other Buildings	279mm [11"]
<b>Maximum Riser– B</b>	
Residences	190mm [7.4"]
Other Buildings	175mm [6.9"]
Maximum no. of risers per flight	15
Minimum Head room under the staircase- C	2m [6'-6"]
Height of the Handrail from center of the tread-D	900mm [3']

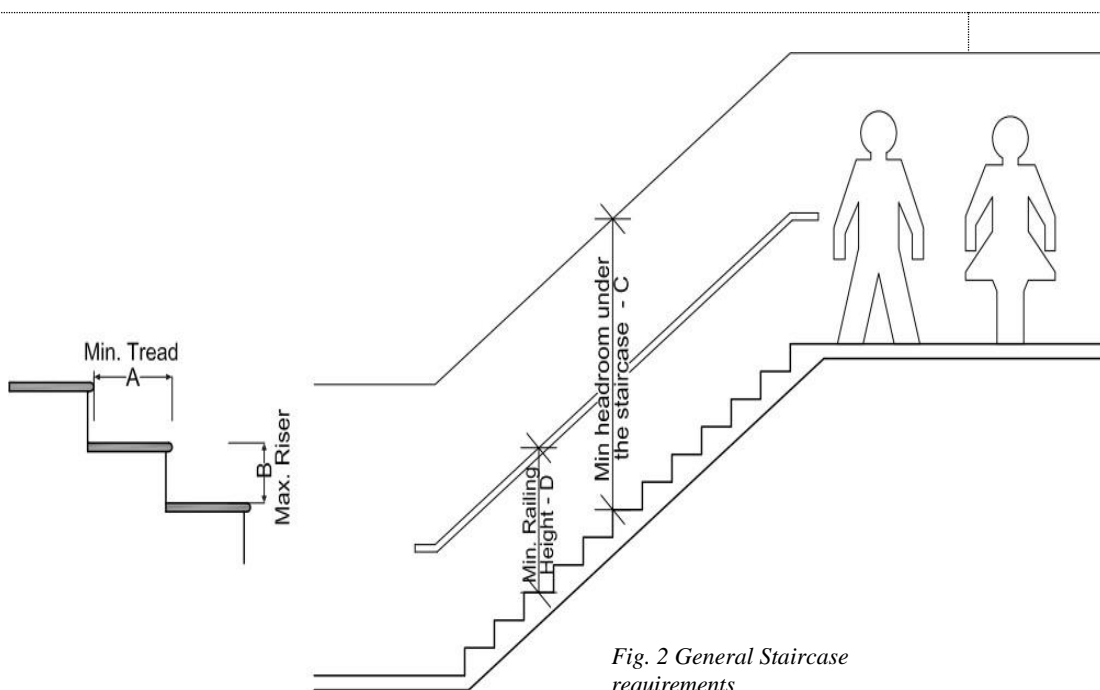

*Fig. 2 General Staircase requirements*

### 3. COMPONENTS OF THE BUILDINGS

#### 3.1 Plinth

Minimum plinth height shall be 450mm from the existing road level for all buildings. The road level can be difficult entity to define as road and site may be in gradient. However, it should be understood that, the main goal of this rule is to ensure that the entry to the building remains above the road level as there is a tendency of road level increasing when they are maintained overtime.

Parking and Garage may have no plinth.

#### 3.2 Minimum Room Dimensions

##### 3.2.1 Height

###### For Residential building

The height of all rooms for human habitation shall not be less than 2.4m measured from the surface of the floor to the lowest point of the ceiling [bottom of slab].

In the case of pitched roof, the average height of rooms shall not be less than 2.4m.

The minimum clear head room under a beam or any such structure including after installation of false ceiling shall be 2.1m.

The height of the bathroom or water closet shall not be less than 2m.

For *Office and Commercial* building, the minimum floor height shall be 2.9m.

Floor heights for *Assembly, Hospitals, Educational and Industrial* buildings shall not be less than 3.2m for *Hill & Mountain* region and 3.6m for *Terai* region.

##### 3.2.2 Size

The minimum size of the room shall not be less than the following:

<b>A. Minimum habitable room Size</b>	Min Dimension	2.0 m
	Minimum Area	6 sq.m
<b>B. Kitchen</b>	Min Dimension	1.8 m
	Minimum Area	5 sq.m
<b>C. Toilet cubicle/ water closet</b>	Minimum dimension:	0.9 m
	Minimum Area:	1.2 sq.m
<b>Bath Room</b>	Minimum dimension:	1.2 m
	Minimum Area:	1.8 sq.
<b>Combined water closet with bath room</b>		1.2 m
	Minimum dimension:	2.8 sq.m
	Minimum Area:	



### 3.3 Light & Ventilations

All habitable rooms shall have the provision to admit natural light and ventilation.

Minimum area of openings (excluding internal doors) for a habitable room towards exterior or into an open verandah shall be as follows

General Openings Requirements	Recommended	Reference size required for 4 m X 4 m room
A. Min. area of openings for natural light	1/10 <sup>th</sup> of the room area for hilly regions 1/8 <sup>th</sup> of the room area for other regions	1.0 X 1.5 1.32 X 1.5
B. Kitchen	25% more than minimum permitted 1/8 <sup>th</sup> of the room area for hilly regions 1/6 <sup>th</sup> of the room area normally	1.32 X 1.5 1.75 X 1.5
C. Min. area of opening for natural ventilation:		
General requirement	1/16 <sup>th</sup> of the room area	0.6 X 1.5
Hospitals: Patient rooms & Schools	1/8 <sup>th</sup> of the room area	1.32 X 1.5

No portion of the room shall be considered naturally lighted if it is more than 7.5 m from the opening assumed for lighting that portion.

Minimum size of internal courtyard from which admission of light is permitted for a habitable room shall be 3m X 3m for normal rise building. For buildings higher than 5 stories the size of courtyard shall increase by 0.5 m or equivalent area for every additional floor or 4 m [whichever is less].

These requirements may be relaxed for building occupancy type other than **Residence, Hospitals and Academic** if the artificial lighting and ventilations are installed to satisfy the needs.

### 3.4 Lifts

Lifts indicate appliance designed to transport persons or material in a vertical direction.

#### A. Lift Provision requirement

- Provision of Lift(s) shall be made for all the buildings above 5 stories or 18 m in height.
- Provision of at least two lifts shall be made for high rise building [above 8 stories or 25 m in height]. At least one of the lifts shall be fire lift that can be used by fire fighter for rescue and access in case of emergency.
- If lifts are provided, at least one of the lifts within the buildings under category 2 and 3 of 'Disabled Accessibility' shall be accessible to the people on the wheel chairs. It may be noted however that provision of lifts for buildings under category 2 is not mandatory while in case of category 3, ramps may substitute for lifts.

**B. Lift Size and Capacity requirement**

- Minimum width of the Category 3 disabled accessible lift car shall be 1250mm X 1400mm while it shall have minimum clear opening of 800 mm.
- Minimum width of Hospital lift car shall be 1200 mm X 2400 mm while having a minimum clear opening of 900 mm.
- A fireman's lift shall have loading capacity of not less than 500 kg [8 persons]. The lift car of the fire lift shall have floor area not less than 1.44 sq.m.

**C. Disabled Accessibility Requirements**

- All lifts shall be accessible without disturbance from the parking and main approach of the building to the wheel chair bound people.
- All disabled accessible lifts within the buildings shall emit audible sound to ease the travel of visually impaired people.
- Height of the controls from the lift floor level shall be at most 1200mm for all disabled accessible lifts.

**D. Fire Safety Requirements**

- Shafts for all lifts shall be closed by walls having fire resistance of two hours.
- The fire lift shall have fire protection and control mechanism as specified under 'Fire safety code – 107'.

**E. Electrical Installation Requirement**

- The electric supply for the fire lifts and Hospital lifts shall be on a separate supply line from the supply mains. In case of failure of normal electric supply, it shall automatically trip over to an alternate power source.
- All lifts in case of power failure shall stall with the door open at the nearest floor to enable the passenger to exit.

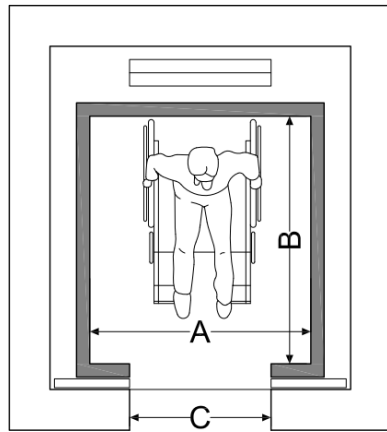

*Min. dimensions of disabled accessible Lift*

A	1250mm
B	1400mm
C	800mm

*Fig. 3 Lift car sizes*

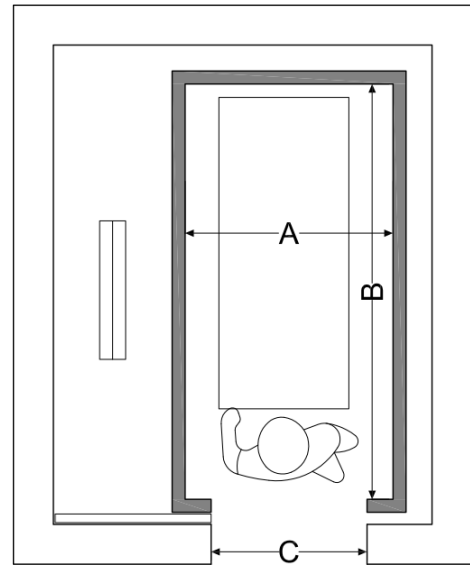

*Min. dimension of Hospital lifts*

A	1200mm
B	2400mm
C	900mm

### 3.5 Basements

Basements are the lower story or storey of a building that are either completely below the average ground level or extending up to 1.2m above the average ground level. Any floor above 1.2m level shall be considered as Semi-basement floor.

#### A. Basic Requirements

- Basement floor shall not be used for residential purpose.
- The minimum height of the basement floor shall be 2.4 m.
- Adequate arrangement shall be made such that surface drainage doesn't enter the basement. The walls and floors of the basement shall be water tight.

#### B. Ventilation Requirements

- Each basement shall be separately ventilated. Vents with cross sectional areas not less 2.5% of the floor area spread preferably around the perimeter of the basement shall be provided through stall boards, pavement light or through shafts [in case of double basements].
- Each basement above 200 sq.m shall have minimum of one each system of air inlets and smoke outlet served through mechanical system. Additional vent system shall be provided for every 200sq.m of plinth area there on.

#### C. Safety Requirements

- The staircase of the basement shall have fire resistance value of not less than 2 hours.
- As specified under section 2.2 maximum travel distances to the stairway or exit shall not be more than 30 m beyond which another means of exit shall be provided. Ramps can be considered as one of the means of access.

### 3.6 Parking

These basic parking requirements shall be applicable to areas where vehicular transport is available and is associated with off street parking:

- The minimum height clearance for indoor parking space shall not be less than 2.2 m.
- For common parking, area allocated for each car shall not be less than 2.5 m X 4.5 m.

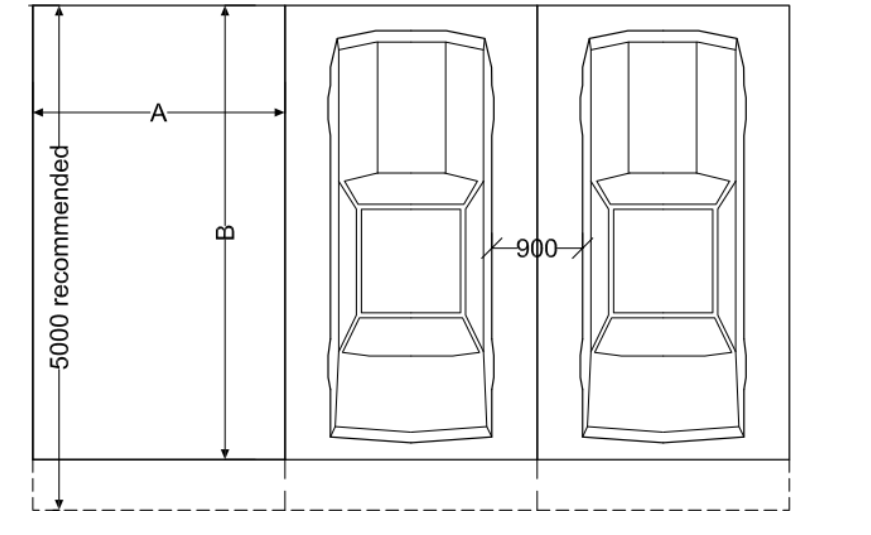

*Minimum area for common parking*

A	2500 mm
B	4500 mm

- Parking area allocated for each bike and scooter shall not be less than 1.25 sq.m while the same for the cycle shall not be less than 1 sq.m.
- The gradient of ramp leading to parking space for occupancy type other than A1 and A2 shall not be more than 1:5.

## 4. SPECIFIC REQUIREMENTS FOR MULTI STOREY BUILDINGS

Under Part 1.2.2 The Multi storey buildings have been categorized into 4 groups. Besides all the above-mentioned requirements the Medium rise and High-Rise building need to follow additional requirement as specified below:

### 4.1 Medium Rise:

These includes buildings between 6 to 8 Storey or between 18 m to 25 m

- A. Lift                      All midrise buildings shall be provided with lift.
- B. Staircase              In all midrise buildings, the main staircase shall be of enclosed type separated for the occupancy area by fire/smoke check door as dictated by fire code 107.  
All midrise buildings shall have provision of emergency or secondary staircase which shall has at least one side open to exterior.  
Spiral staircase shall not be permitted as means of exit.
- C. Parapet                Minimum height of Parapet shall be 1 m excluding finishing.

### 4.2 High Rise

These includes buildings between 9 to 39 storey or 25 m to 100 m

- A. Lift                      In all high-rise buildings minimum of two lifts shall be provided. At least one of the lifts shall be fire lift that can be used by fire fighter for rescue and access in case of emergency. The requirement of fire lifts has been briefly covered under Section 3.4.
- B. Staircase              All High-Rise buildings shall have the provision of secondary or emergency staircase regardless of occupancy type which shall have at least one side open to exterior. Pressurized staircase can be used as emergency staircase.  
All High-Rise buildings above 50 m shall have at least one staircase which should be pressurized and fire proof as dictated by fire safety code 107.  
External staircases for high-rise buildings are not recommended because of vertigo effect on people. The external staircases shall not be used on the buildings above 50 m.
- C. Restrictions          Buildings under Subgroup A1 & A2 [Individual Residences and residences with limited commercial use] are not allowed.  
School buildings & Medical institutions under subgroup D2 shall not be allowed.
- D. Refuge Area            Refuge area of at least 10 m<sup>2</sup> or area equivalent to 0.2 m<sup>2</sup> per occupant shall be provided on the 10<sup>th</sup> storey or the storey at 25 m level whichever comes first. The same shall be provided after every 4 stories or 15 m interval whichever comes first. The no of occupant shall be calculated considering the occupant load of 2 storeys above and below the refuse area.  
As far as possible the refuge area shall be in central area adjoining the main fire lift or fire staircase and shall have at least one wall as external face of the building. The refuge area shall be as specified under 'Fire Safety Code-107'

E. Parapet Minimum height of Parapet shall be 1.2 m excluding finishing.

## 5. ACCESSIBILITY FOR DISABLED

The main goal of this section is to make all or part of the public buildings and facilities used by the public accessible to and functional for the physically challenged people of the society.

The major portion of accessibility for disabled covers wheel chair bound people. It is assumed that by making the buildings accessible for such people, they are automatically accessible to the other differently able people

### 5.0.1 Requirements for Wheelchair bound people

The average size of the Standard manual wheel chair is **640mm-700mm X 900-1100 mm**. To measure door clearance, we add 50 mm to each side to leave room for hands. Which means doorways designed for use by disabled people shall have at least **800 mm** clear opening while the recommended size is **900 mm**. Any reference to disabled accessible doorways and entrance under category 1, 2 and 3 shall meet this requirement.

In general, to rotate 1-wheel chair full 180° minimum space required is 1500 mm in diameter. This is the standard space required for fully wheel chair accessible public facilities including Public toilets, hospitals, ATM counters

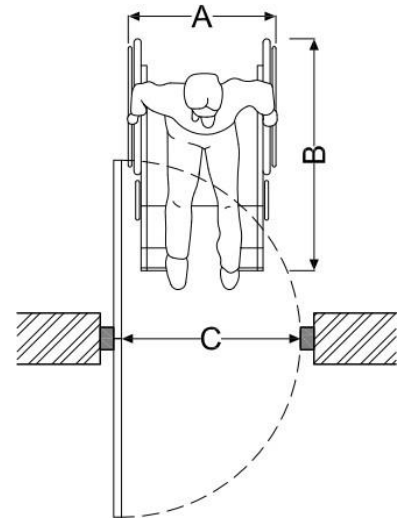

Fig. 4 Standard wheelchair and doorway size

A	640-700mm
B	900-1100mm
C	800mm

Accessibility requirements for the disabled have been

addressed by categorizing the buildings into three categories each of which are required to fulfill set of provisions.

### 5.1 Category 1: Minimally Accessible

- All government & semi-government public buildings and dormitories with plinth area below 100sq.m.

Required Provisions

- At least one entrance of category 1 public building shall be accessible to the wheelchair bound people and he should be able to access the reception area and any public service or facilities provided by the building. The person shall also be able to access at least one of the toilets. As such, any public service units, the reception area and at least one of the toilets shall be located on the Ground floor or the floor that accessible from approach.
- A. Ramps
- Minimum gradient of **1:8 [7 degrees]** for the difference in height not more than 450 mm.
  - Minimum gradient of **1:12 [5 degrees]** for the difference in height more than 450 mm.

- Shall have level platforms for every **1.5 m** of vertical rise. The level platform shall not be less than 1.2 m in length and the same width as the ramp.
  - Minimum width of ramp shall be **1 m**.
- B. Sanitary Facilities
- Shall have at least 1 toilet with Commode.
  - Shall have door with minimum clear opening of 800 mm.

## 5.2 Category 2: Partially Accessible

- All government and semi-government buildings with plinth area between 100 sq.m & 500sq.m.
- All forms of Health posts and Hospitals under sub group D1 [less than 25 beds].
- Commercial & Office buildings with plinth area between 250 sq.m & 500 sq.m
- All secondary level school (more than class 5)
- To all assembly buildings with occupancy higher than 500 persons.

### Required Provisions

- At least one primary entrance to a building shall be usable by the physically disabled and the disabled person should be able to access the reception area, ground floor and the toilet. Although provision of lift is not compulsory for category 2 buildings, if provided, it should be accessible to person on wheel chair. As such, in absence of lift all the public oriented services, reception area and at least one disabled accessible toilet shall be provided on the ground floor or the floor that is accessible from approach.
- Assembly area above 500 persons capacity [either as an individual building or as a part of other building] shall be accessible to the wheel chair bound people.

### A. Ramps

- Minimum gradient of **1:8 [7 degrees]** for the difference in height not more than 450 mm.
- Minimum gradient of **1:12 [5 degrees]** for the difference in height more than 450mm.
- Should have level platforms **for 1.5 m** of vertical rise. The level platform shall not be less than 1.2 m in length and the same width as the ramp.
- Level platforms should be provided at tops and changes of directions.
- Minimum width of ramp shall be **1 m**.
- Handrails shall be provided if total rise exceeds **1 m** and should be positioned between 850 mm and 1 m above the surface of such ramp.
- Should have non-slippery surface.

### B. Openings

- Shall have flush threshold or at maximum threshold limit shall not exceed 12 mm
- Minimum clear width in openings: 800 mm
- Minimum clear width in main openings: 900 mm



- The control or handle to the door at major doors should be placed between 900-1200 mm from the floor

C. Sanitary  
Facilities

- Should have at least 1 water closet for the wheel chaired bound person that is at minimum:
  - 900 mm wide
  - 1600 mm deep
  - Shall have Commode
  - Shall have door with minimum clear opening of 800 mm.

The water closet can be unisex.

D. Cinema Hall/  
Auditoriums

- Every hall above capacity of 500 should be able to accommodate min of 3 wheel chaired person for every 500 people

E. Lifts

- The minimum required size of disabled accessible lift is provided under part 2.2.4
- All lifts shall have audible sound to enable easy movement for the visually impaired.
- Height of the controls from the floor level of the lift car shall be at most 1066 mm

### 5.3 Category 3: Fully Accessible

- All Hospital under Sub-Group D2 [more than 25 beds]
- All public building with plinth above 500 sq.m
- Commercial & Office buildings with plinth area above 500 sq.m



*Fig. 5 International sign for disabled accessibility. Such signs shall be used in important area of fully accessible buildings under category 3*

Besides the requirement under part 4.1.2, all habitable part of the building should be fully

accessible to the disabled either through lifts or ramps. The lifts shall meet the minimum standard for disabled accessibility as described under heading 3.4.

Other requirement includes:

- For every 20 toilet compartments, there should be 1 full disabled accessible toilet. It is to be noted that the disabled accessible toilet can be unisex. All the Sanitary fixtures shall be as guided by NBC Code.
- Symbol indicating disabled accessibility [fig 11] shall be in place at lift, toilets, main exits, parking areas. This symbol should be in contrasting colour and properly illuminated so that it can be easily identified visually impaired people.
- Lift should fulfill the minimum requirements for disabled accessibility as specified under heading 3.4 C.

## 6. SUMMARY OF REQUIREMENTS BASED ON OCCUPANCY

This section intended as a quick reference for individual building category and in most cases refers to previous sections. It may however contain requirements which have not been specified in previous section.

### 6.1 Residences

S. No.	Elements of building	Particular dimensional aspects	General Residence	Residence with limited com. use	Apartments	Dormitories	Reference
1.	Occupancy load	Maximum area per Occupant	11.5 sq.m	9 sq.m	18 sq.m	6 sq.m	2.1
2.	Exit	Maximum distance to exits or stairways within single floor			30 m		2.2
		Minimum size of the Doorway		0.9 m X 2 m or as per Table 2			2.2.1
		Width of the corridors		As per Table 3			2.3
		Staircase width		As per Table 3			2.4
		Staircase Designs		Shall confirm with 2.4.1			
3.	Components of Building	Plinth	Min. 450 mm from existing road level				3.1
		Minimum Room Dimensions	Refer 3.2				
		Light & Ventilations	Refer 3.3				
		Lifts	As per midrise & high-rise requirements				3.4 & 4.
		Basements	Refer 3.5				

## 6.2 Assembly

S. No.	Elements of building	Particular dimensional aspects	Standard	Reference
1.	Occupancy load	Maximum area per Occupant	1.4 sq.m net	2.1
2.	Egress	Maximum distance to exits or stairways within single floor	30 m 40 m for external corridor	2.2
		Doorway	As per Table 2	2.2.1
		Width of the Corridors	As per Table 3	2.3
		Staircase & Ramp width	As per Table 3	2.4
		Staircase Designs	Shall confirm with 2.4.1	
3.	Components of Building	Minimum Floor Height	3.2 m at any point for Hills & Mountains 3.6 m for Terai region	3.6
		Parking Requirements	Min. 1 car park for every 25 persons Min. 1 bike park for every 10 persons	Refer local byelaws
5.	Accessibility for Disabled	Provisions for disabled Mandatory for capacity above 500	Provision for 3 wheel chaired person for every 500 people Shall fulfill the requirement of Category 2	5.

### 6.3 Educational

S. No.	Elements of building	Particular dimensional aspects	Primary Schools	Others	Reference
1.	Occupancy load	Maximum area per Occupant	4.0 gross		2.1
2.	Egress	Maximum distance to exits or stairways within single floor	30 m 40 m for external corridor		2.2
		Width of the Doorway	As per Table 2 No door shutter shall exceed 1.2 m in width		2.2.1
		Width of the Corridors	As per Table 3		2.3
		Staircase width	As per Table 3		2.4
		Staircase Designs	Shall confirm with 2.4.1		
3.	Components of Building	Plinth	Min. 450 mm from existing road level		3.1
		Minimum Height of the room	2.75 m	3.2 m for Hills & mountains 3.6 m for Terai	3.2.1
		Light & Ventilations	Refer 3.3		
4.	Specific requirement	Minimum area per student			
		For individual seats	None	1.2 sq.m	
		For bench seats	1 sq.m	1 sq.m	
		Maximum Distance between black board and Last row of benches	7 m		
		Minimum Distance between black board and The first row	none	2 m	
		Sanitary Units	NBC 208 Table B10		
5.	Accessibility for Disabled	For schools with students	none	Shall fulfill the requirement of category 2	5.2

#### Recommended areas and lighting requirements for various units

S. No.	Unit	Minimum Standard	Lighting[lux]	Remark
1.	Library	Mandatory for every school with 500 or more students	100	
	Minimum Capacity	10% of total students		
	Area per student	2.4 sq.m per student		
2.	Science Lab	4 sq.m per student	200	
	Other Laboratory	2.4 sq.m per student		
	Art Room	2.7 sq.m per student	100	
3.	Teacher's Room	1.8 sq.m per student		

4. Boarding Accommodation		
Dormitories	2.8 sq.m per bed in double bunk	
Dining Hall	1 sq.m per student	70
Kitchen & Annexes	.36 sq.m per student	80
Urinals/Toilets	1 per 15 students	
Wash Basin	1 per 20 students	
Showers	1 per 20 students	

Referenced from "Guideline or Architecture Design & Approval of School/ College"

## 6.4 Hospitals and Clinic

S. No.	Elements of building	Particular dimensional aspects	Less than 25 beds	More than 25 beds	Reference	
1.	Occupancy load	Maximum area per Occupant [Sq.m]	14 sq.m	14 sq.m	2.1	
2.	Egress	Maximum distance to exits or stairways within single floor	30 m	40 m for external corridor	2.2	
		Doorway	Width as per Table 2		2.2.1	
			Doors of Operation suite and Delivery suite shall be two leaf type with min. width of 1.5 and shall have self-closing devices			
		Width of the Corridors	As per Table 3		2.3	
		Staircase width	As per Table 3		2.4	
		Staircase Designs	Shall confirm with 2.4.1			
3.	Components of Building	Plinth	Min. 450 mm from existing road level		3.1	
		Minimum Height of the room	3.2 m for Hills & mountains 3.6 m for Terai		3.2.1	
		Light & Ventilations	Min area of opening for natural ventilation shall be 1/6 <sup>th</sup> of the room area Other requirements shall confirm with 3.3		3.3	
		Lifts	Min. size of patient lift car: 1.2 m X 2.4 m		3.4	
		Accessibility for Disabled	Shall fulfill the requirement of Category 2	Shall fulfill the requirement of Category 3	5.	

### 6.5 Commercials& Office

S. No.	Elements of building	Particular dimensional aspects	Commercials	Offices	Reference
1.	Occupancy load	Maximum floor area per Occupant [Sq.m] Main floor & Basement Other floors	2.75sq.m 5.5sq.m	9sq.m	2.1
2.	Egress	Maximum distance to exits or Stairways within single floor Width of the Doorway Width of the Corridors Staircase width Staircase Designs	30 m 40 m for external corridor As per Table 2 As per Table 3 As per Table 3 Shall confirm with 2.4.1		2.2 2.2.1 2.3 2.4
3.	Components Of Building	Minimum Height of the room Light & Ventilations Basement Parking Requirement	2.9 m Refer 2.2.3 Refer 3.5 Refer 3.6		3.2.1
4.	Accessibility for Disabled		Refer 5.0		



## 6.6 Industries& Storage

S. No.	Elements of building	Particular dimensional aspects	Industries	Storage	Reference
1.	Occupancy load	Maximum floor area per Occupant [Sq.m]	9 sq.m	28 sq.m	2.1
2.	Egress	Maximum distance to exits or Stairways within single floor	30 m 40 m for external corridor		2.2
		Width of the Doorway	As per Table 2 No door shutter shall exceed 1.2 m in width		2.2.1
		Width of the Corridors	As per Table 3		2.3
		Staircase width	As per Table 3		2.4
		Staircase Designs	Shall confirm with 2.4.1		
3.	Components of Building	Minimum Height of the room	3.2 m for Hills & mountains 3.6 m for Terai		3.2.1
		Light & Ventilations	Refer 2.2.3		
		Basement	Refer 3.5		
4.	Accessibility for Disabled		None		

**A. REFERENCES**

- National Building Code of India -2005
- National Building Code of India -2016
- International Building Code-2009
- National Building Code of the Philippines (P.D. 1096)
- 2010 ADA (Americans with Disabilities Act) Standards for Accessible Design
- Building Codes Illustrated, Francis D.K Ching/ Steven R Winkel
- Byelaws for municipalities & urbanizing VDCs within Ktm Valley-2064
- Neuferd Architect's Data, Third Edition

## B. GENERAL CHECKLIST FOR NBC-206

	BUILDING ELEMENT	As per submitted Design	Remarks
<b>1.</b>	<b>CLASSIFICATION OF BUILDING</b>		
	Building Purpose		
	Sub Group		
<b>2.</b>	<b>MEANS OF EXIT</b>		
	Effective Occupant Load for exit calculation		
	Max. travel distance to exit point in each floor(m)		
	Min. width of exit door including frame (mm)		
	Min. height of the exit door including floor (mm)		
	No. of staircase and Ramps		
	Total Width of the Staircase/ Ramps(mm)		
	Tread of Staircase (in mm)		
	Riser of Staircase (in mm)		
	Max. no. of riser on one single flight (Nos)		
	Height of the Hand Rail (in mm)		
<b>3</b>	<b>COMPONENT OF BUILDING</b>		
3.1	Average Plinth height (mm)		
3.2	Room Height (m)		
3.3	Light & Ventilation		
	Min. ratio of opening area for natural light(O) to area of habitable room (A) – (O/A)		
	Min. ratio of opening area for natural ventilation (O) to area of habitable room(A) – (O/A)		
3.4	Lifts		
	Presence of fire lift	<input type="checkbox"/> Yes <input type="checkbox"/> No	
	Size of Lift car(m)		
3.5	Basements		
	Percentage of vent. in basement		
3.6	Parking		
	Parking area allocated for each car (L X B) (mm)		
	Gradient of ramp for vehicle use		
<b>4.</b>	<b>BUILDING CATEGORY BASED ON HEIGHT</b>		
	Height of parapet wall or balcony handrail(m)		
	Provision of fire escape and fire safety	<input type="checkbox"/> Yes <input type="checkbox"/> No	
<b>5.</b>	<b>DISABLED ACCESSIBILITY CATEGORY</b>	None/1/2/3	
	No. of floors accessible to wheel chair bound people		
	Max. gradient of ramp		
	Min. width of ramp(m)		